

DOCUMENT NAME: PRODUCT SPECIFICATION	SUBJECT: RF SWITCH 2.5*2.5 CONNECTOR	DOCUMENT NO: SPEC-RSAC-0001			
		PAGE	1 OF 15	REV	X1

PRODUCT SPECIFICATION

NO.SPEC-RSAC-0001

RSAB CONNECTOR
(Product NO.RSAC-S212-01)

	APPROVED	CHECKED	PREPARED	ISSUED BY :
By	Alvin Zhang	Ease.zhang	Y.Wang	
Date	2023-03-06	2023-03-06	2023-03-06	

***** REVISION HISTORY *****

DOCUMENT NAME: PRODUCT SPECIFICATION	SUBJECT: RF SWITCH 2.5*2.5 CONNECTOR	DOCUMENT NO: SPEC-RSAC-0001			
		PAGE	2 OF 15	REV	X1

Rev.	ECN NO.	Date	Revision Page No.	Notes
X1	20230306	2023-03-06	New Reversion	初次发行
A				
B				
C				
D				
E				
F				
G				
H				
J				
K				
L				
M				
N				
P				
Q				
R				
S				
T				
U				
V				
W				
Y				
Z				

DOCUMENT NAME: PRODUCT SPECIFICATION	SUBJECT: RF SWITCH 2.5*2.5 CONNECTOR	DOCUMENT NO: SPEC-RSAC-0001			
		PAGE	3 OF 15	REV	X1

1. Application(应用) :

This SMT type Microcoaxial RF Rec. products are designed for Mobile phones, Wireless LAN, Mini-PCI, Bluetooth, PDA, GPS, electronic measuring instruments, etc

该系列产品设计用于移动电话, 无线 LAN, Mini-PCI, 蓝牙, PDA, GPS, 电子测量仪器等等.

2. Scope(范围) :

This Product Specification covers the requirement of Mini RF VI Switch Connector on product performance, test methods and quality assurance provisions.

本规格书内容涵盖 Mini RF 第 2 代开关型同轴连接器产品的要求, 包括性能指标、测试方法及质量保证方面等.

3. Technology Parameters(技术参数) :

3.1 Frequency Range(频率范围) :	DC~11GHz
3.2 Nominal Characteristic Impedance(特性阻抗) :	50 +/-5 Ohm
3.3 Power Rating(额定功率) :	2W
3.4 V. S. W. R(电压驻波比) :	1.2 Max. (0.1~3GHz); 1.3 Max. (3~6GHz); 1.5 Max. (6~11GHz);
3.5 Insertion Loss(插入损耗)-NC State:	-0.1dB Max. (0.1~3GHz); -0.2dB Max. (3~6GHz);
3.6 Isolation(隔离度)-NO State:	-0.6dB Max. (6~11GHz); -20dB Min. (0.1~3GHz); -15dB
3.7 Operating Temperature Range(工作温度范围) :	Min. (3~6GHz); -10dB Min. (6~11GHz);
3.8 Operating Humidity(工作湿度) :	-40°C~+85°C

4. 产品构成/材料 CONSTRUCTION AND MATERIAL.

95% R. H. MAX

4.1 下主体 DOWN HOUSING	: 热塑性塑胶 (PLASTIC)
4.2 上主体 TOP HOUSING	: 热塑性塑胶 (PLASTIC)
4.3 内端子 IN CONTACT	: 不锈钢 (stainless steel)
4.4 外端子 OUT CONTACT	: 不锈钢 (stainless steel)
4.5 外壳 SHELL	: 铜合金 (Copper Alloy)

DOCUMENT NAME: PRODUCT SPECIFICATION	SUBJECT: RF SWITCH 2.5*2.5 CONNECTOR	DOCUMENT NO: SPEC-RSAC-0001			
		PAGE	4 OF 15	REV	X1

5. Ratings(额定性能要求)

- 5.1 Voltage Rating(额定电压) : 250V AC (R.M.S)
- 5.2 Initial Insulation Resistance(绝缘电阻) : 500 M Ohm
- 5.3 Withstand Voltage(耐电压) : 300V AC 1 Min.
- 5.4 Contact Resistance(接触电阻) :
 - 5.4.1 Inner Contact (内导体) (扣除导体电阻) : 120 m ohm
Max. (Without conductor resistance)
 - 5.4.2 Outer Contact (外导体) : 20 m ohm Max.
- 5.5 Durability(耐久性): 500 Cycles.

6. Electrical Performance(电性性能):

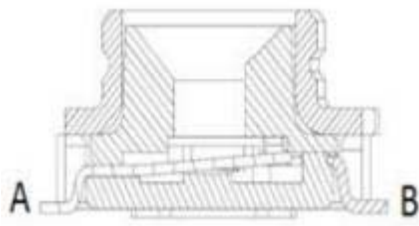
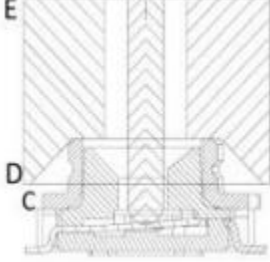
NO.	Items (项目)	Test Condition (测试条件)	Specifications (规格)
6.1	Low Level Contact Resistance 接触阻抗	(EIA 364-23) Testing by the voltage dropping method with the low level current. 按照 EIA364-23 要求, 采用低电平压降方式测量电阻值。 Open circuit voltage 开路电压: 20mV MAX Circuit current 电流: 100mA MAX *Note: Test Methods are as following Figure1 and Figure 2, Body Resistance is eliminated here. 备注: 测试方法参照图 1 和图 2, 此处的接触电阻测试 不包括体电阻。	Inner contact 中心导体 : Initial 初始 120mΩ Max.* : After 测试后 150mΩ Max.* Ground contact 外导体 : Initial 初始 20mΩ Max.* : After 测试后 50mΩ Max.*
		Inner contact /中心导体: RAB	Ground contact/外导体: RCE - RDE
		 <p style="text-align: center;">Figure 1</p>	 <p style="text-align: center;">Figure 2</p>

DOCUMENT NAME: PRODUCT SPECIFICATION	SUBJECT: RF SWITCH 2.5*2.5 CONNECTOR	DOCUMENT NO: SPEC-RSAC-0001			
		PAGE	5 OF 15	REV	X1

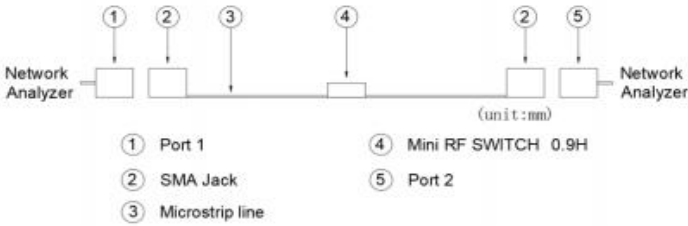
6.2	Insulation Resistance 绝缘阻抗	(EIA 364-21) Testing by applying the specified voltage (DC 200 V) between the inner and ground contacts for one minute. 在内外导体之间施加 200V DC 的电压, 测试时间 1 分钟。	Initial 初始: 500 MΩ MIN After 试验后: 100 MΩ MIN
6.3	Dielectric withstanding voltage 耐电压	(EIA364-20) Testing by applying the specified voltage(AC 300 V) between the inner and ground contacts for one minute. 在内外导体之间施加 300V AC 的电压, 测试持续 1 分钟。	No evidence of breakdown 无瞬断、熔闪、击穿
6.4	V. S. W. R* (电压驻波比)	Measurement system is as following figure 3 and tested by network analyzer. Frequency: DC~11GHz 如图 3 所示, 通过网络分析仪测试; 频率范围 DC~11GHz;	1.2 Max. (DC~3GHz); 1.3 Max. (3~6GHz); 1.5 Max. (6~11GHz)
 <p style="text-align: center;">(unit:mm)</p> <p style="text-align: center;">① Port 1 ④ Mini RF SWITCH 0.9H ② SMA Jack ⑤ Port 2 ③ Microstrip line</p> <p style="text-align: center;">Figure 3</p>			
6.5	Insertion Loss (NC) 插入损耗	Measurement system is as following figure 3 and tested by network analyzer. Frequency: DC~11GHz 如图 3 所示, 通过网络分析仪测试; 频率范围为 0.1~11GHz; Note: the loss of the other conductive part than the receptacle is not included. 注: 除产品外的所有其它导体引起的损耗被消除。	-0.1dBMax. (DC~3GHz); -0.2dBMax. (3~6GHz); -0.5dBMax. (6~11GHz)
6.6	Isolation 隔离度	Measurement system is as following figure 4 and tested by network analyzer. Frequency: DC~11GHz 如图 4 所示, 通过网络分析仪测试; 频率范围为 0.1~11GHz; Note: the manual testing probe should be inserted to the mating portion of the receptacle completely during the testing. 注: 此项测试中, 需要使用手动测试公头, 并保证完全插配到母座上。	20dBMin. (DC~3GHz); 15dBMin. (3~6GHz); 10dBMin. (6~11GHz)

DOCUMENT NAME: PRODUCT SPECIFICATION	SUBJECT: RF SWITCH 2.5*2.5 CONNECTOR	DOCUMENT NO: SPEC-RSAC-0001			
		PAGE	7 OF 15	REV	X1

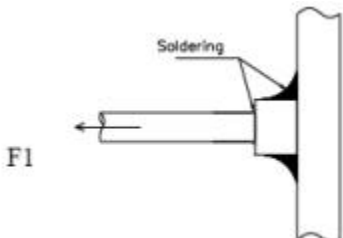
7.4	Adhered of Electrode Terminal 焊点保持力	<p>Soldering test sample with test PCB . Measurement conditions are as followings according to figure 5: 将产品已正常焊接工艺焊在 PCB 上, 按图 5 方式在下列条件下测量: 1. Force (拉力) :F1=40N 2. Time (时间) :5+/-1s.</p>	<p>No excoriation of electrode terminal 焊接端子无明显脱落</p>
			
7.5	Vibration 机械振动	<p>Apply the following vibration conditions to the mating connector. During the testing, run 100mA DC to check electrical discontinuity. Frequency:10Hz → 100Hz → 10Hz/approx 20minutes. Half amplitude, Peak value of acceleration: 3mm or 60m/s² (6G). Directions, cycle:3 mutually perpendicular direction, 3 cycles for each direction. 将公母头配合, 并施加如下条件测试. 在测试期间, 施加 100mA DC 电压, 并检验电不连续性. 频率: 10Hz→100Hz → 10Hz/20minutes. 半振幅、加速度: 3mm、60 m/s² (6G) 方向和循环次数: 每个互相垂直方向上进行 3 次测量</p>	<p>Appearance: No abnormality 外观: 无损伤; Contact Res. : Shall meet 6.1 接触电阻: 满足节 6.1 的要求; No discontinuities of 10 μ s or longer. 电不连续性不超过 10 μ s.</p>
7.6	Shock 机械冲击	<p>EIA 364-27 Condition A The object of this test procedure is to detail a standard method to assess the ability of a connector to withstand specified severity of mechanical shock. Test Current:100mA. Peak value of acceleration:750m/s² (75G) Duration:6ms Wave form : half sinusoidal Directions, cycle : 6 mutually perpendicular direction, 3cycles about each direction 此测试程序的目的是要作一详细标准以评估连接器能承受特定严格机械冲击的能力. 振幅峰值, :750m/s² (75G) 持续时间: 6 毫秒波型: 半正弦波, 方向和循环次数: 每 6 个相互垂直方向上各进 3 次. 通电 100mA 测试电不连续性.</p>	<p>Appearance: No abnormality 外观: 无损伤; Contact Res. : Shall meet 6.1 接触电阻: 满足节 6.1 的要求; No discontinuities of 10 μ s or longer. 电不连续性不超过 10 μ s.</p>

DOCUMENT NAME: PRODUCT SPECIFICATION	SUBJECT: RF SWITCH 2.5*2.5 CONNECTOR	DOCUMENT NO: SPEC-RSAC-0001			
		PAGE	8 OF 15	REV	X1

8. Environmental Performance(环境性能):

NO.	Items (项目)	Test Condition (测试条件)	Specifications (规格)
8.1	Humidity 恒温恒湿 试验	<p>(MIL-STD-202, Method 103 Test Condition B) Test is done without mating adaptor , apply the following environment to the mating connector. Temperature : 60°C. Humidity : 95%R.H. Duration: 96 hours(50hours*). Note: The condition is under the “*” value when test is done with adaptor. Measurements should be done within 2 hours. 在未用转接器插合状态下,根据 MIL-STD-202 试验条件 B 中的第 103 方法,对已配合的连接器施加下列条件测试。 温度: 60°C; 湿度: 95%R.H; 持续时间: 96 小时(50 小时*); 备注: 1)在有转接器插合状态下测试时间“*”值。 2)所有测量应在完成湿度试验 2 小时内进行。</p>	<p>Appearance: No abnormality 外观: 无损伤; Contact Resistance: shall meet 6.1 接触电阻: 满足 6.1; Insulation Resistance: shall meet 6.2 绝缘电阻: 满足 6.2; Dielectric withstanding voltage shall meet 6.3 耐电压: 满足 6.3</p>
8.2	Thermal Shock 冷热冲击	<p>(MIL-STD-202, Method 107 Test Condition) Apply the following environment to the mating connector as following: -50°C (30min)~25°C (5max) ~ 90°C (30min) ~ 25°C (5max) Transition time: 5min. MAX Cycles: 50 Cycles 根据 MIL-STD-202, 按如下试验条件对已配合的连接 器 施加下列条件测试。 循环: -50°C (30min)~25°C (5max)~90°C (30min) ~25°C (5max) 转换时间: 5 min Max. 循环次数: 50 次数</p>	<p>Appearance: No abnormality 外观: 无损伤; Contact Resistance: shall meet 6.1. 接触电阻: 满足节 6.1 中的要求; Insulation Resistance: shall meet 6.2 绝缘电阻: 满足节 6.2 中的要求; Dielectric withstanding voltageshall meet 6.3. 耐电压: 满足节 6.3 中的要求。</p>
8.3	Solderability 可焊性	<p>Apply the following environment to the mating connector Temperature : 245±5°C Duration : 3~5 second Test sample should be observed by the magnification of 10times after the test. 按下列条件对已配合的连接器进行测试。 温度: 245+/-5°C 持续时间: 3~5 秒钟。观测: 10 倍放大镜</p>	<p>At least 95% covered by a continuous new solder coating. 吃锡面积大于 95%以上。</p>

DOCUMENT NAME: PRODUCT SPECIFICATION	SUBJECT: RF SWITCH 2.5*2.5 CONNECTOR	DOCUMENT NO: SPEC-RSAC-0001			
		PAGE	9 OF 15	REV	X1

8.4	Resistanc e to soldering heat 耐焊接热	According to the following conditions to test connector. 1. Infrared reflow soldering, the peak temperature of 260 degrees Celsius, reference temperature curve, and the requirements of the SMT2 time; 2. electric soldering iron, requires 300 degrees 5 seconds, 350 degrees below 3 seconds. 按下列条件进行测试: 1. 红外线回流焊接, 峰值温度 260 度以下, 可 参 考温度曲线图, 且要求 SMT2 次; 2. 电烙铁焊接, 要求 300 度 5 秒, 350 度 3 秒以下。	Appearance: No abnormality. 外观无明显损伤; Coplanarity of the solder tail should be not beyond 0.10mm 焊脚平面度不超 0.10mm。
8.5	Salt Spray 盐 雾测试	(EIA 364-26 Test Condition A) Apply the following environment to the mating connector Temperature : 35±2°C Relative Humidity : 90~98%R.H Salt water density: 5±1% Duration : 48 hours for contact area 根据 EIA364-26 试验条件 A 中的要求, ,对已配合的连 接器施加下列条件测试: 温度: 35±2°C; 相对湿度: 90~98%R.H; 盐水浓度: 5±1%; 持续时间: 48 hours; (端子接触区)	Appearance: No abnormality 外观: 无损伤; Contact Resistance: Shall meet 6.1 接触电阻: 满足节 6.1 中的要 求

9. Others (其它)

NO.	Items (项目)	Matter (事项)
9.1	Connectio/ disconnecti on of connectors 连接器的连接 和断开	a).To mate the connectors, the mating axis of both connectors must be aligned and the connectors can be mated fully, until they can' t be moved. Not allowed in a very tilt mating angle and do not bend coaxial cable in the measuring procedure, otherwise you' ll get a not good test data. b).To disconnect connectors, please disengage them along the axis direction of mating hole, until they' re separated completely. With the point of insertion of allowed and when force is applied as shown in Figure 6 a). 公母头连接器进行配合前, 务必确保两者对齐, 对插到死点位置 为止, 表示两 者已完全配合在一起, 不要以极偏的角度插配连接器, 测试使用 过程中, 请不要将 同轴线折弯, 否则可能会影响测试效果。 b) 断开时请尽量沿配合开口的轴向方向竖直拔起线端公头直至两者完全 脱离为止, 对插时允许的配合角度和施加力如图 6 所示。

DOCUMENT NAME: PRODUCT SPECIFICATION	SUBJECT: RF SWITCH 2.5*2.5 CONNECTOR	DOCUMENT NO: SPEC-RSAC-0001			
		PAGE	10 OF 15	REV	X1

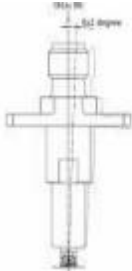
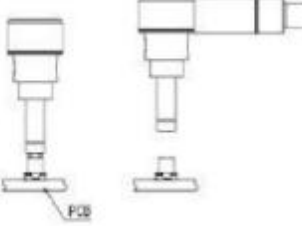
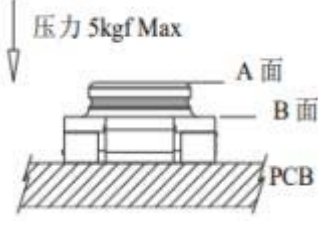
NO.	Items (项目)	Matter (事项)
9.1	Connection/ disconnecti on of connectors 连接器的连接 和断开	<p>Type A  Type B: </p> <p style="text-align: center;">Figure 6</p>
9.2	Precautions 禁忌	<p>a) Please mount this product at the position so that stress by wrap and/or bend of the PCB may not apply to it. b) Please avoid the cleaning of this product c) The product can't be in the longtime compression and the pressure on surface no more than 2Kgf. Please refer to figure 7</p> <p>a) 产品安装位置处不应有 PCB 翘曲和/或弯曲施加应力。 b) 请避免清洁此产品 c) 产品表面所承受压力最大不能超过 2 Kgf, 且不能处于长久受压状态. 请参照图 7 所示。</p> <p style="text-align: center;"></p> <p style="text-align: center;">Figure 7</p>
9.3	Stockpile condition 存储条件	<p>Use this product within 6 months after receipt Condition : Temp: -10~+40℃ Humidity:15~85%</p> <p>有效期: 请在产品接收后的 6 个月内使用 存储环境: 温度:-10~+40℃; 湿度:15%~85%</p>

DOCUMENT NAME: PRODUCT SPECIFICATION	SUBJECT: RF SWITCH 2.5*2.5 CONNECTOR	DOCUMENT NO: SPEC-RSAC-0001			
		PAGE	11 OF 15	REV	X1

10. Recommended Reflow Soldering Condition/SMT(推荐的回流焊接温度曲线图) :

10.1 Recommended Temp.&Time of Reflow

Soldering 建议回流焊温度与时间条件

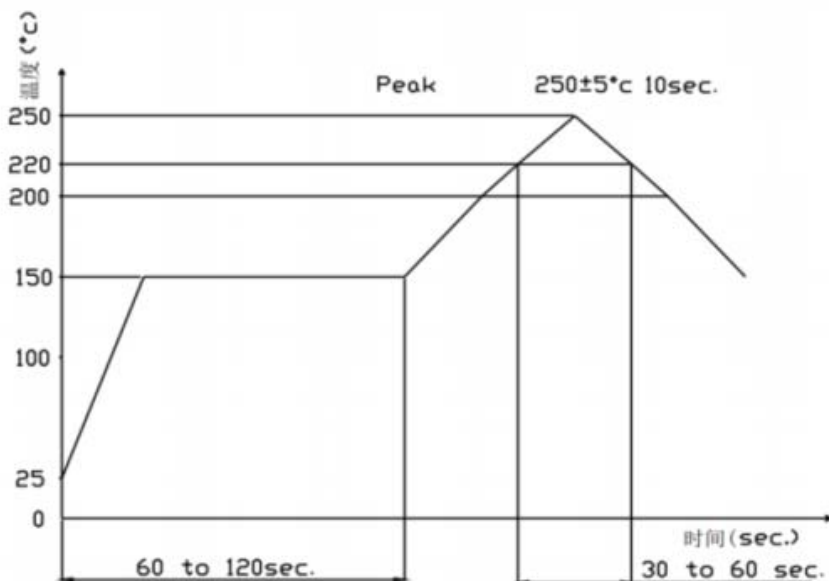

10.2 Reflow Soldering Standard Condition

回流焊极限温度与时间条件

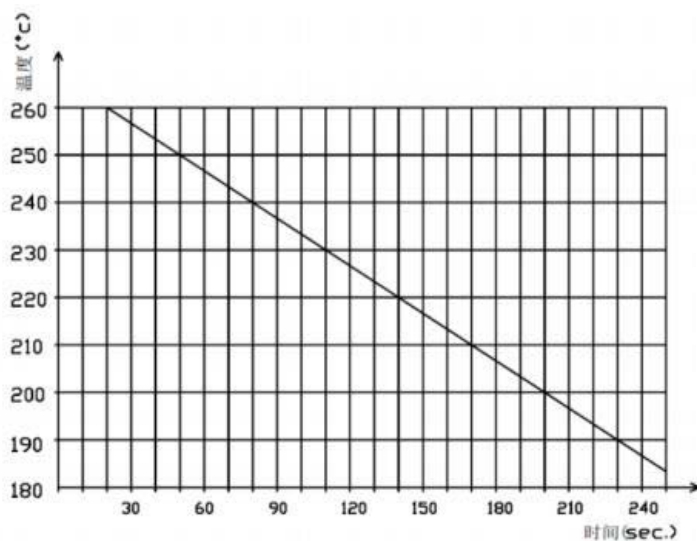

DOCUMENT NAME: PRODUCT SPECIFICATION	SUBJECT: RF SWITCH 2.5*2.5 CONNECTOR	DOCUMENT NO: SPEC-RSAC-0001			
		PAGE	12 OF 15	REV	X1

11. Receptacle Profile Dimensions (外形规格)

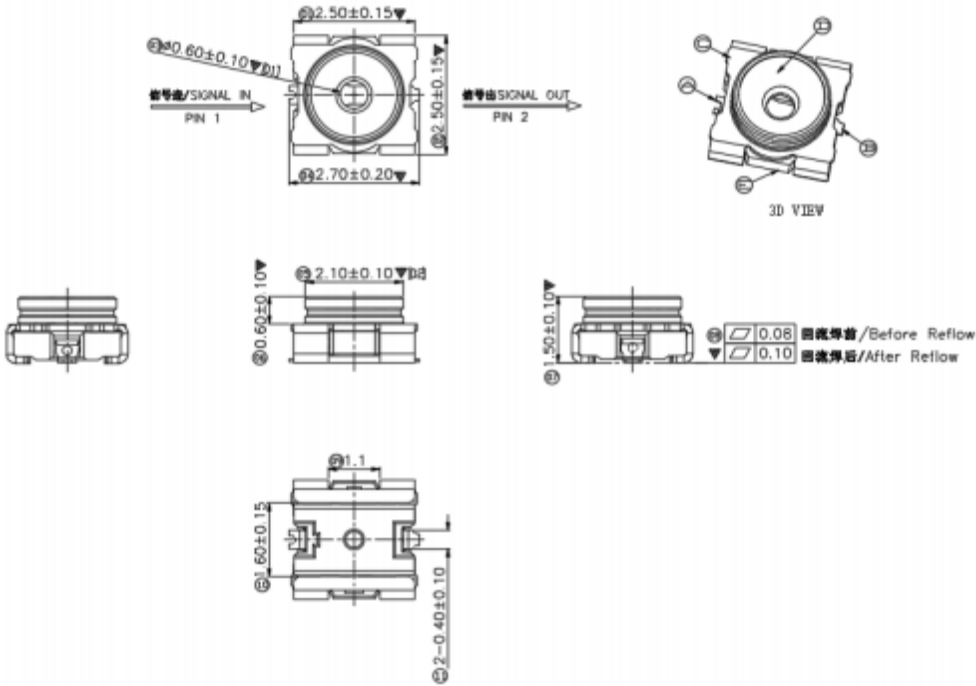

12. Recommended PCB Layout And Metal Mask (推荐的 PCB 安装焊盘及钢网规格) :

12.1 Recommended PCB Layout 推荐的 PCB 安装焊盘:

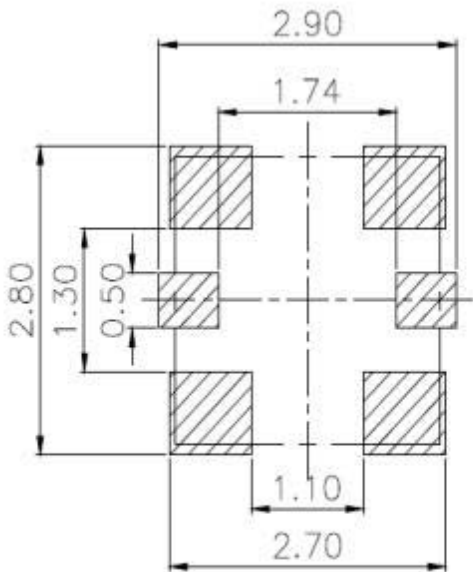

推荐的PCB布局/Recomed PCB Layout
一般公差/General Tolerance: ± 0.05

DOCUMENT NAME: PRODUCT SPECIFICATION	SUBJECT: RF SWITCH 2.5*2.5 CONNECTOR	DOCUMENT NO: SPEC-RSAC-0001			
		PAGE	13 OF 15	REV	X1

12.2 Recommended Metal Mask 推荐的钢网规格:

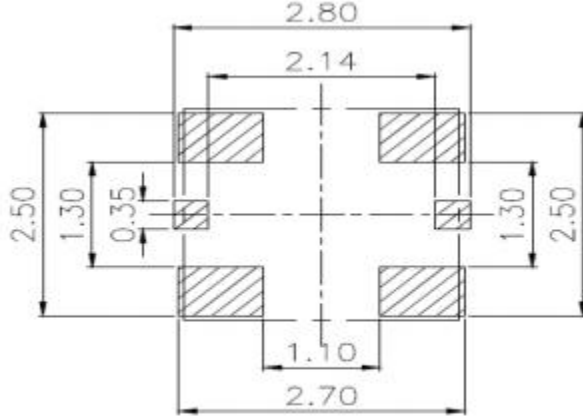

推荐钢网/RECOMMEND METAL MASK
(钢网厚度/Mask thickness 0.12mm)

13. Packaging(包装) :

13.1 The pull force of the tape: Pull the tape at the speed of 300mm/min, the pull force is 1.3N Max.
上带的剥离力度: 300mm/min 的速度进行剥离, 力度最大应该是 1.3N.

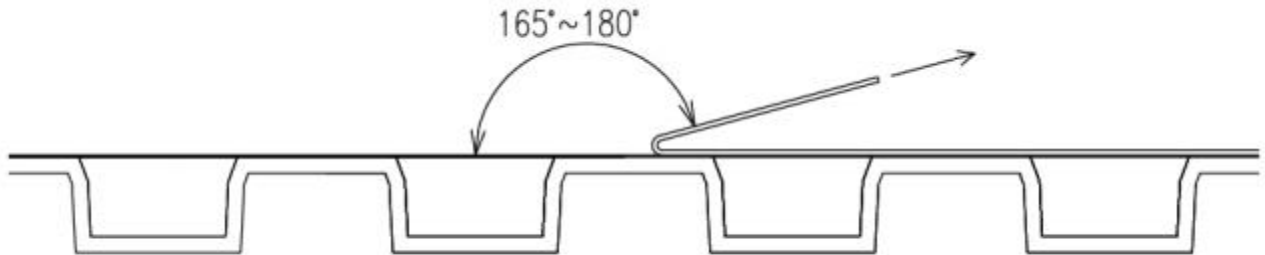

13.2 Packaging type: Tape&Reel, 3000Pcs/R(Φ178mm) .

包装方式: 载带包装, 3000Pcs/卷(Φ178mm)

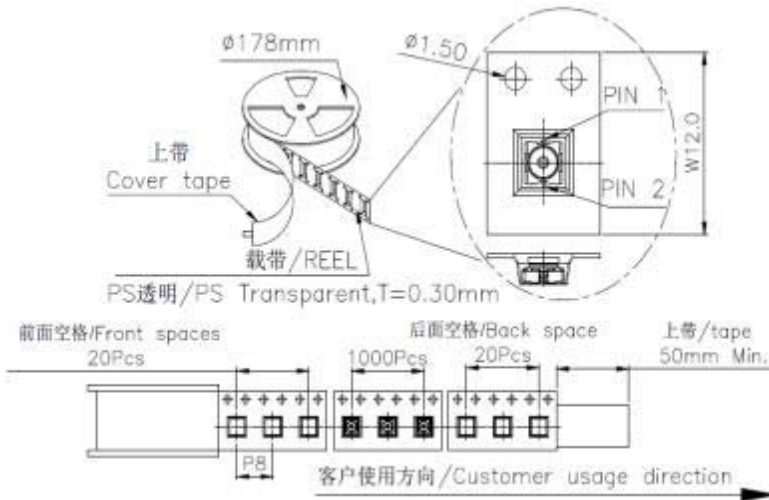

DOCUMENT NAME: PRODUCT SPECIFICATION	SUBJECT: RF SWITCH 2.5*2.5 CONNECTOR	DOCUMENT NO: SPEC-RSAC-0001			
		PAGE	14 OF 15	REV	X1

14. Recommended Mating test Probe (推荐的测试探针):

Type A:

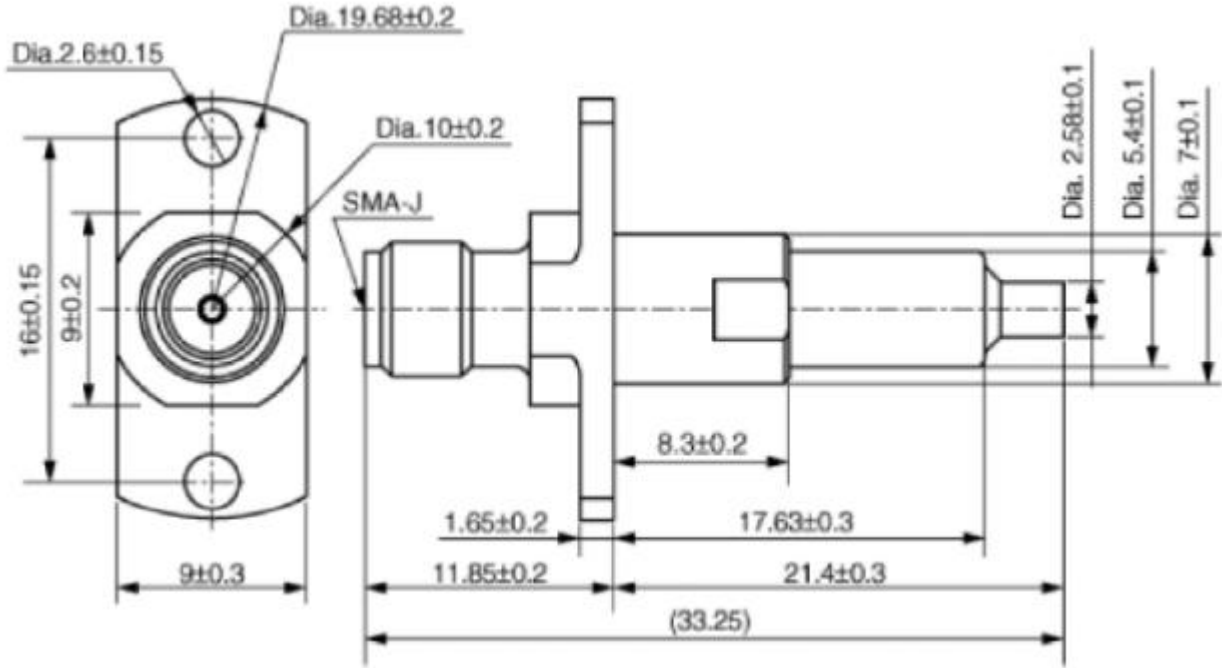

Type B:

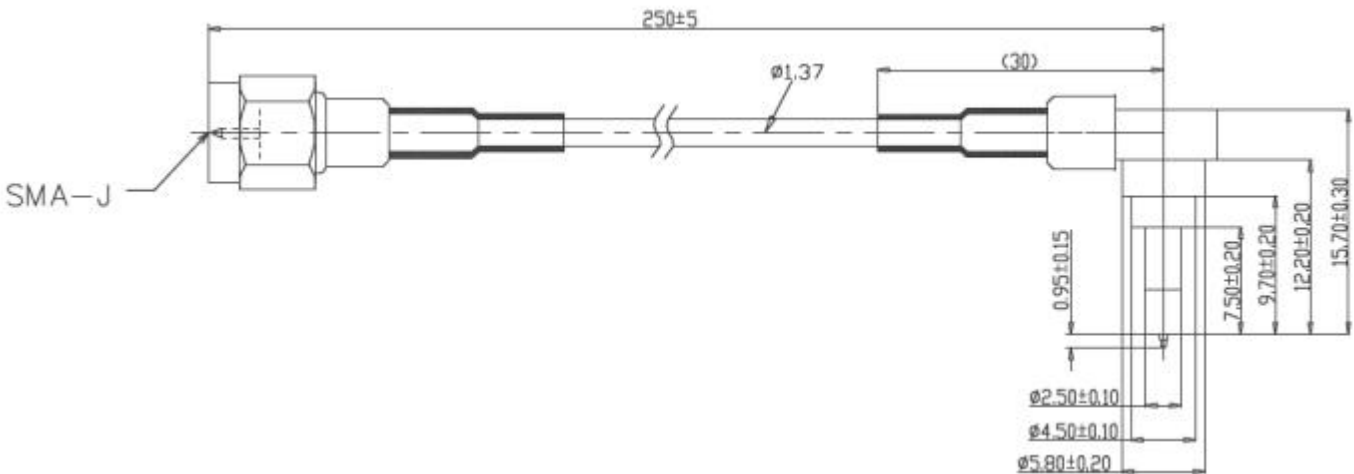

DOCUMENT NAME: PRODUCT SPECIFICATION	SUBJECT: RF SWITCH 2.5*2.5 CONNECTOR	DOCUMENT NO: SPEC-RSAC-0001			
		PAGE	15 OF 15	REV	X1

15. Test Sequence and Sample Quantity (测试顺序及样品数量)

序号	Test Item (测试项目)	Group (测试分组)											
		A	B	C	D	E	F	G	H	I	J	K	L
1	Examination of product 外观检测	1, 11	1,	1, 3	1	1	1, 6	1	1, 3	1, 3	1, 5		
2	Contact Resistance 接触电阻	2, 12			2, 4	2, 4	2, 7	2, 7			2, 4		
3	Insulation Resistance 绝缘电阻	3					3, 8	3, 8					
4	Dielectric withstanding 耐电压	4					4, 9	4, 9					
5	V. S. W. R* 电压驻波比	5, 13											
6	Insertion Loss 插入损耗	6, 14											
7	Isolation 隔离度	7, 15											
8	Mating/un-mating Force 插拔力	8, 10											
9	Allowed Push Force 接触压力		2, 4										
10	Durability 机械寿命	9	3										
11	Adhered of Electrode 焊点粘接力			2									
12	Vibration 振动				3								
13	Shock 冲击					3							
14	Humidity 湿度试验						5						
15	Thermal Shock 冷热冲击							5					
16	Solder ability 可焊性								2				
17	Resistance to soldering 耐焊接热试验									2			
18	Salt Spray 盐雾测试										3		
19	Sample QTY (PCS) 样品数量	5 PCS	5 PCS	5 PCS	5 PCS	5 PCS	5 PCS	5 PCS	5 PCS	5 PCS	5 PCS	5 PCS	5 PCS

The number of group is test sequence 测试分组中的序号为试验顺序。